

Commercial Aluminum Slider HS-C30

Standard Features

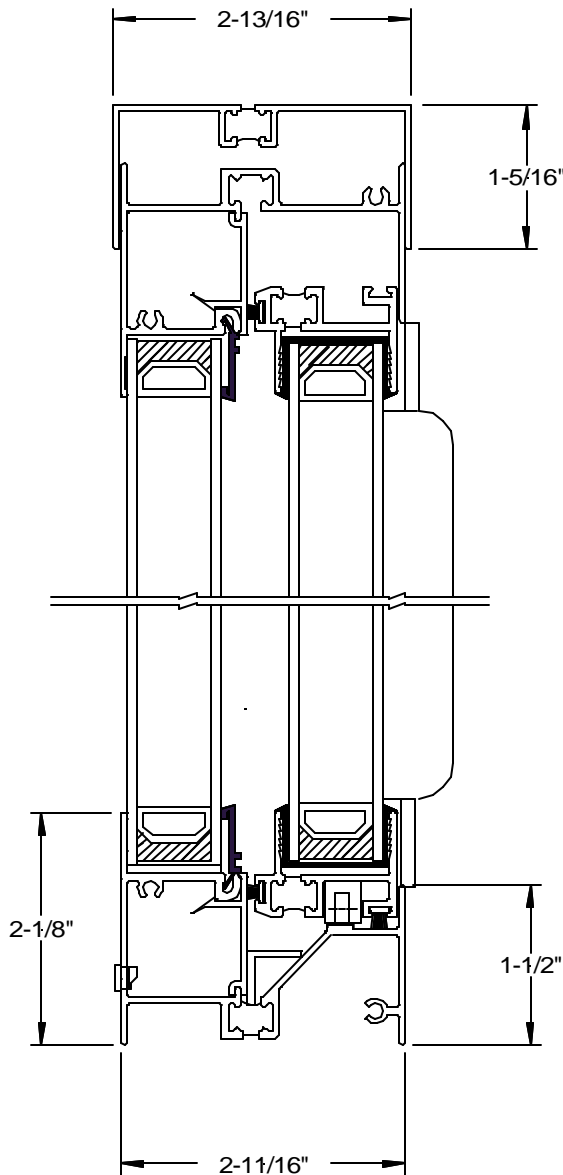

- 2-5/8" Frame Depth
- T-6063 Aluminum Extrusions with .062" walls
- Thermally Broken Frame and Sash
- Factory Glazed with 7/8" Insulated Glass with Super Spacer[®] warm edge spacer technology for superior thermal performance.
- Spring Loaded Clip Locks securely engage the jamb
- Equal Leg Frame
- Finseal Dual Weatherseals on active sash
- Fixed Lite is interior glazed with channel glazed active sash – both are field serviceable.
- Architectural paint finish meets AAMA 2603. Colors available for normal lead times: White, Bronze, Tan, and Clear Anodized. For large projects, custom colors are available on a special order basis – please contact our office for details.
- Active sash glides smoothly on double brass rollers on a extruded aluminum track.
- Active sash lifts out for cleaning.
- Strong Extruded Aluminum center frame bar
- Available with nail fin for new construction or without nail fin for replacement applications.
- Head Expander is available if required.

Optional Features

- Extruded Aluminum Screen for long service life
- Numerous high performance glazing options
- Mullion for multiple units
- Many Grid Between Glass (GBG) configurations are available for greater design flexibility and low maintenance.
- Three Section (XOX) configurations are available.
- Optional Face Flange
- HS-R50 Version is available

The Westco Slider's versatility makes it the perfect solution when a sliding window is required. It has been used in a variety of applications for many years, including schools, hotels, motels, residences, porch and room enclosures, and as serving windows, just to name a few. This window is available in two section (XO) and three section (XOX) and is custom manufactured to your specifications, delivered in a timely manner, and can help make your project a complete success.